



**European
Gymnastics**

Head Office
Avenue de la Gare 12
CH - 1003 Lausanne

Phone: +41 - 21 - 613.10.20

info@europeangymnastics.com
www.europeangymnastics.com

DIRECTIVES FOR EQUIPMENT



TEAMGYM

Edition 2022



Introduction

The TeamGym Equipment Directives have been updated in September 2021 to reflect the changes to the Landing Zone and the positioning of the CD judges for Floor. Some clarifications and corrections have also been made.

The Equipment Directives establish the minimum requirements for gymnastic apparatus used for the TeamGym European Championships.

One of the most important objectives is to ensure that the apparatus norms reflect an organised and safe sport.

In addition to the Equipment Directives, the TC-TG are also preparing Equipment Standards for the TeamGym equipment. Where possible, the Equipment Standards will be based on the FIG Equipment Norms.

As the performance test for the Trampet is not yet in place, the TC-TG will only approve trampets that have been tested and evaluated at various international competitions. This process includes feedback from many gymnasts and coaches on the performance as well as the safety characteristics.

The plan is to publish updated TeamGym Directives for Equipment and new TeamGym Equipment Standards in 2022.

© Drawings European Gymnastics

All members of European Gymnastics TeamGym Committee (TC-TG) contributed to this revision.

Per Sjöstrand	President TC-TG
Heli Lemmetty	Vice President
Peter Tranckle	Secretary
Max Andersen	Member
Pauline Ange	Member
Bianca Franzoi	Member
Petr Gryga	Member

Abbreviations

The following abbreviations will appear throughout the document:

LOC	Local Organising Committee
TC-TG	European Gymnastics Technical Committee for TeamGym
FIG	International Gymnastics Federation



Contents

Art 1	GENERAL.....	4
Art 2	SUMMARY OF EQUIPMENT.....	4
Art 3	THE EQUIPMENT.....	5
3.1	FLOOR.....	5
3.2	TUMBLE	6
3.2.1	TUMBLE TRACK	6
3.2.2	LANDING AREA	6
3.2.3	SAFETY STRIPS.....	6
3.2.3	ADDITIONAL SAFETY MAT	7
3.2.4	APPROACH RUN-UP	7
3.3	TRAMPET	7
3.3.1	THE TRAMPETS	8
3.3.2	VAULTING TABLE.....	10
3.3.3	LANDING AREA	11
3.3.4	SPACE ISSUES	11
3.3.5	ADDITIONAL SAFETY MAT	11
3.3.6	APPROACH RUN-UPS.....	11
3.3.7	LAYOUT OF TRAMPETS	12
Art 4	CHECKING APPARATUS.....	12
Art 5	THE APPENDICES.....	12
	Appendix A1 Competition Hall Layout.....	13
	Appendix A2 Competition Equipment Dimensions	14
	Appendix A3 Trampet and Vault Details	15

Copyright © 2021 All
rights reservedv1.0 –
September 2021



Art 1 GENERAL

These Directives establish the minimal requirements for gymnastic apparatus used for the TeamGym European Championships.

The Local Organising Committee (LOC) of a TeamGym Championships shall provide for all the necessary apparatus, which shall be in conformity with the European Gymnastics TeamGym Directives for Equipment.

The LOC should present detailed equipment proposals for approval by the TC-TG.

Art 2 SUMMARY OF EQUIPMENT

The following equipment should be provided:

Floor A competition floor

Tumble A Tumble Track, with run-up and landing area

Trampet A set of trampets, a vaulting table, with run-ups and a landing area All

equipment should be new. Trampets must be new.

The preferred configuration is shown in Appendix A1 – Competition Hall Layout. This requires a hall with a minimum size of 40 m by 28 m.

An identical set of equipment must be provided in the training hall, which must be close by, together with suitable matted warming up facilities for all teams.

Art 3 THE EQUIPMENT

3.1 Floor

The floor exercise shall be performed on a 35 mm (+5/-0 mm) thick mat of carpet-bonded foam, with a marked performing area of 14 m x 16 m.

The outline of the performing area shall be marked with a 5 cm non-slip whiteline. This should be either painted or fixed to the mat with Velcro. The white line is part of the performing area and must be within the carpet-bonded foam area.

The area is preferable made up of 9 mats, 2 m wide and a minimum 14 m long. Alternative configurations could be approved a minimum of 6 months before the competition.

The mats shall be homogeneous and continuous. They shall be connected on their adjacent edges with 10 cm wide non-slip Velcro strips in matching colour to the mats, or a similar way of securing the mats are connected correctly. The Velcro strips shall be continuous and shall extend to the ends of the mat. The mats shall be placed in such a way as to avoid any movement or shift during the event. They shall be antistatic.

The TC-TG in collaboration with the LOC shall previously agree the colour.

Any banners and/or advertising signs may be fixed with Velcro to the free area, but there must be a significant colour difference. The advertising banners should not be less than 10 cm from the outside of the white line.

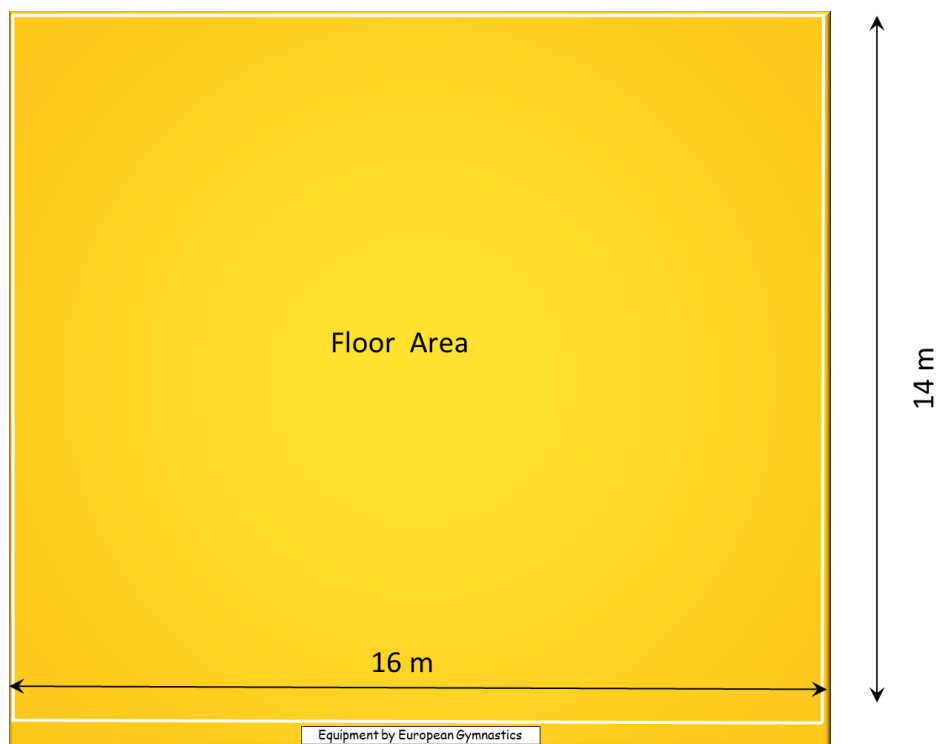



3.2 Tumble

The equipment shall be composed of:

- An approach run-up
- A tumble track
- A landing area
- Safety areas
- An additional safety mat
- A fixed tape measure

3.2.1 Tumble Track

The performing area of the tumble track shall be 15 m long (+/- 10 cm). It must be a contrasting colour to the run-up, the landing area and the supplementary mat.

The track shall be a minimum of 2 m (+/- 5 cm) wide and 35 cm high (+/- 5 cm).

The surface of the tumble track shall be completely even and without folds or joints. The side-lines and centre line should be marked with non-slip white lines 5 cm wide. The side-lines are part of the 2 m wide performing area.

3.2.2 Landing Area

The landing area shall be 7 m long and 4 m wide.

The landing area can be made of several standard mats of the appropriate size and construction. There must be no mat connections across the surface of the Landing Zone. It must be the same height as the tumble track (+/- 5 mm). The mats must be designed for safe reception and absorption of the landing force.

The landing area has a Landing Zone 1.5 m by 3 m (+/- 5 cm) marked in a contrasting colour.

The mats must be connected with at least a 10 cm Velcro flap. The Velcro connections should connect away from the gymnasts' movement direction and not cause any trip hazards.

The underside of the landing area shall be non-slip, so it will not move during use.

The tumble track shall be connected to the landing area with at least a 15 cm Velcro flap. The run-up shall be connected to it with at least a 10 cm Velcro flap.

3.2.3 Safety Strips

The safety strips are located at the sides of the track, near to the landing area.

They are each at least 0.5 m wide and a minimum of 3 m long. They shall start at the landing area and shall be fixed with a Velcro flap (min 10 cm) on both sides of the tumble track.



3.2.3 Additional Safety Mat

An Additional Safety Mat is an optional soft mat 2 m by 4 m and 10 cm thick. The Safety Mat shall include the same contrasting colour of the 1.5 m by 3 m Landing Zone. It shall be possible to connect the safety mat to the front end of the landing zone, with a Velcro connection (10 – 15 cm). On the tumble track's Velcro flap, there must be soft Velcro on the upper side to connect the safety mat to it, if required.

3.2.4 Approach Run-up

The approach run-up shall be 16 m (+/-5 cm) long, measured from the start of the performing area, restricted with a limiter, if required. It shall be 1 m (+/-5 cm) wide and level with the tumble track (+5/-0 mm).

It shall be covered with a non-slip material. The run-up shall be fixed in such a way as it will not move or slide during the gymnasts' rapid movements. Blocks that form the run-up shall, if required, be connected with Velcro flaps.

There shall be a smooth transition between the run-up and the Tumble Track.

A 31 m tape measure must be attached to the floor at the side of the run-up so as not to cause a trip hazard. It will measure the distance from the start of the landing area. Adjacent to the run-up, each meter should be marked with large numbers so as to be clearly visible from the run-up. No personal markings will be allowed on the run-up, the track or on the floor.

3.3 Trampet

The equipment shall be composed of:

- A set of trampets
- A vaulting table
- A landing area
- An approach run-up to the trampet
- A separate approach run-up to the vault
- Additional safety mats
- A tape measure

The LOC shall provide a set of identical trampets for the training area and competition area, which meet the specification in 3.3.1.

As the performance test for the TeamGym trampet is not in place at the moment, the TC-TG will only approve trampets that have been tested and evaluated at various international and national competitions.

There must be trampets of at least two different tensions to choose from. These trampets will be clearly labelled Hard or Soft (or similar). The soft trampet usually has 36 steel springs and the hard trampet usually has 40. At each location, training and competition, there will be two trampets of each tension (in total at least eight trampets).

It is not allowed for teams to bring their own trampets.

3.3.1 The Trampets

General

A TeamGym trampet is a heavyweight mini trampoline. Open-ended/lightweight trampets are not acceptable. Heavyweight is more than 55 kg, measured ready to use, but without safety covers.

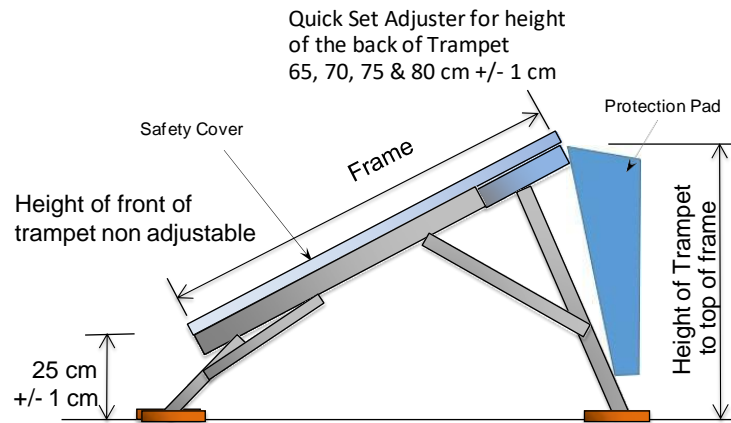

Frame

The top frame shall be constructed of round, square or rectangular hollow tube, approximately 5 cm thick. Legs and supporting parts can be made of larger profiles. No sharp edges are allowed.

Dimensions

The outside measurements of the top frame should be 120 cm (+/- 5 cm).

Height

Front part. 25 cm (+/- 1 cm), non-adjustable.

Back part. 65 to 80 cm range in quick set heights of 65cm, 70 cm, 75 cm and 80 cm (+/- 1 cm).

Springs

Only steel springs are acceptable. See the description of spring set-up under trampets.

Bed of trampet

60 cm x 60 cm (+/- 5 mm). A light-coloured bed clearly different from the colour of the safety cover.

The centre of the bed should be clearly marked. For example: a circle, a plus sign or a cross - see below. The bed should be made of a tight weave material, where the maximum dimension of the holes is 6 x 6 mm.

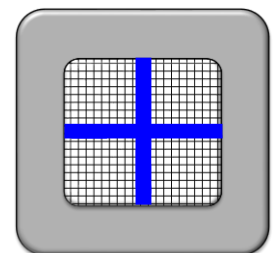
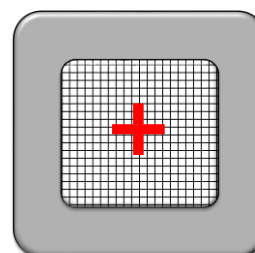
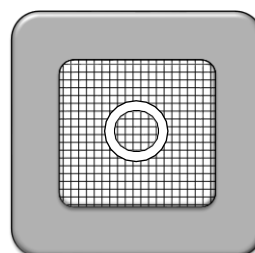



Bed construction	<p>The bed must be constructed from light coloured bands, webs, strings etc., which must be held together in such a way that they are not displaced during use.</p> <p>Width of web under tension: 6 mm +/- 2 mm. Width of strings under tension: 3 mm +/- 1 mm.</p> <p>The strands of webbing (or string) must be sewn together, and the distance between any two strands must not be greater than 8 mm (max: 6 mm with string-construction).</p> <p>The bed must be strong enough to withstand wear and not tear when in use. Trampet beds are subject to considerable changes in dimensions due to the high tensions. All length specifications shall be fulfilled at the following instant of times:</p> <p>At the time of the officially announced apparatus control before the competitions. During other official apparatus controls at 20° C (+/- 3°) and a humidity of <60%.</p>
Safety Cover	<p>The frame and springs must be entirely covered by shock absorbing padding with a minimum thickness of 3 cm. The padding must not cover any part of the bed and the colour must be clearly different from the bed. The free square space in the middle has a maximum size of 68 x 68 cm. The padding should be firmly fixed to the frame without hindering the normal action of the bed and the springs. Nor should it cause noise through flapping. The bottom of the padding at the side of the bed should not protrude above the bed by more than 6cm.</p>
Protection Pad	<p>A vertical protection pad is mandatory in the form of a piece of foam that protects the gymnasts from landing directly on, or falling back onto, an exposed part of the trampet. The protection must be at least 3 cm thick.</p>
Feet	<p>All four feet shall have a non-slip surface with a minimum size of 10 cm by 10 cm. The trampet may not move during use. The stand-alone trampet shall be set close to the landing area such that its feet are beneath the landing area.</p>
Wheels	<p>The trampets must have transport wheels on the one side, which must be stable during transportation.</p>
Tension	<p>The tension in the bed must meet the standards set out in the European Gymnastics TeamGym Equipment Standards for the Trampet (under development).</p>

3.3.2 Vaulting Table

Type	The vaulting table shall comply with the latest European Gymnastics equipment norms, adjustable from 145 cm to 165 cm.
Height	All teams may use the vault at a variable height from 145 cm to 165 cm. The height is measured from the top of the wooden plate to the centre part of the table. The vault shall have a quick and easy height adjustment in 5 cm steps, with marked height settings.

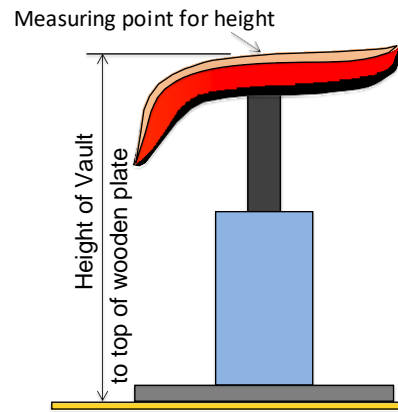

Top part	In accordance with the FIG Apparatus Norms.
Construction	The structure part supporting the vaulting platform shall be a mono-stand. There shall be a height scale on the column, and it shall have transport wheels.
Stability	In order to ensure safe usage, the vault should always be able to pass the European Gymnastics TeamGym Equipment Standards stability test.
Trampet brackets	The vaulting table should have adjustable brackets to maintain the distance of the trampet feet from the front of the vault. There should be quick adjustment in 25 mm settings, between zero and 350 mm, with clear markings. Alternatively, variable blocks could be considered by the TG-TC.
Safety	The leg and the construction beneath the vault should have safety padding on the front, back and sides



3.3.3 Landing Area

The landing area shall be a combined area for the trampet vault and the trampet on its own. The landing area shall be 7 m long and 7 m wide.

The landing area can be made of several standard mats of the appropriate size and construction. There must be no mat connections across the surface of the Landing Zone. It shall be 35 cm high (+/- 2 cm). They must be designed for safe reception and absorption of the landing force.

The mats shall be connected with at least a 10 cm Velcro flaps. The Velcro connections should connect away from the gymnasts' movement direction and not cause any trip hazards.

The landing area has two Landing Zones 1.5 m by 3 m (+/- 5 cm), plus a Safety Zone and additional Safety Mats.

The Landing Zones shall be marked in contrasting colour and it shall be possible to connect the additional safety mat over them with Velcro at the front edge. For certain events, European Gymnastics, may stipulate the colours of the different zones.

The underside of the landing area shall be non-slip, so it does not move during use.

3.3.4 Space Issues

In less favourable circumstances, where only one trampet run-up is possible, a trampet landing area can be created 7 m x 4 m. In such circumstances the vault would need to be moved in and out during the performance. In this situation, it will be announced with the details of the equipment.

3.3.5 Additional Safety Mat

The additional Safety Mat is an optional soft mat 2 m by 4 m and 10 cm thick. The Safety Mat shall include the same contrasting colour of the 1.5 m by 3 m Landing Zone. It shall be possible to connect the safety mat to the front end of the landing area, with Velcro (10 – 15 cm). There will be a mat for each Landing Zone.

3.3.6 Approach Run-Ups

The approach run-ups shall be 25 m (+/- 5 cm) long (restricted to 25 m with a limiter) and 1 m (+/- 5 cm) wide.

The run-up-mats shall be 25 mm (+5/-0 mm) thick.

They shall be covered with non-slip material and they shall be fixed in such away as not to move or slide during the gymnast's rapid movements.

A tape measure must be attached to the floor between the two run-ups so as not to cause a trip hazard. It will measure the distance from the start of the landing area. Adjacent to the run-up, each meter should be marked with large numbers so as to be clearly visible from the run-up. No personal markings will be allowed on the run-up or on the floor.



3.3.7 Layout of Trampets

The diagram in Appendix A3 shows a felted non-slip timber plate beneath the trampets and the vault, which is the same thickness as the run-up mat. The run-up mat shall be fixed in position and taped to this plate with no gap.

Please note that the trampet and vault will therefore be raised 25 mm above the floor. An adjustable bracket on the vault will be provided to maintain the position of the trampet to the vault, as required by each team

Art 4 CHECKING APPARATUS

A representative of the TC-TG shall check the apparatus before the competition starts and shall authorise its use provided that the safety and technical requirements conform to the regulations.

Art 5 THE APPENDICES

A1 Competition Hall Layout

A2 Competition Equipment Dimensions
A3 Trampet Details

Appendix A1 Competition Hall Layout

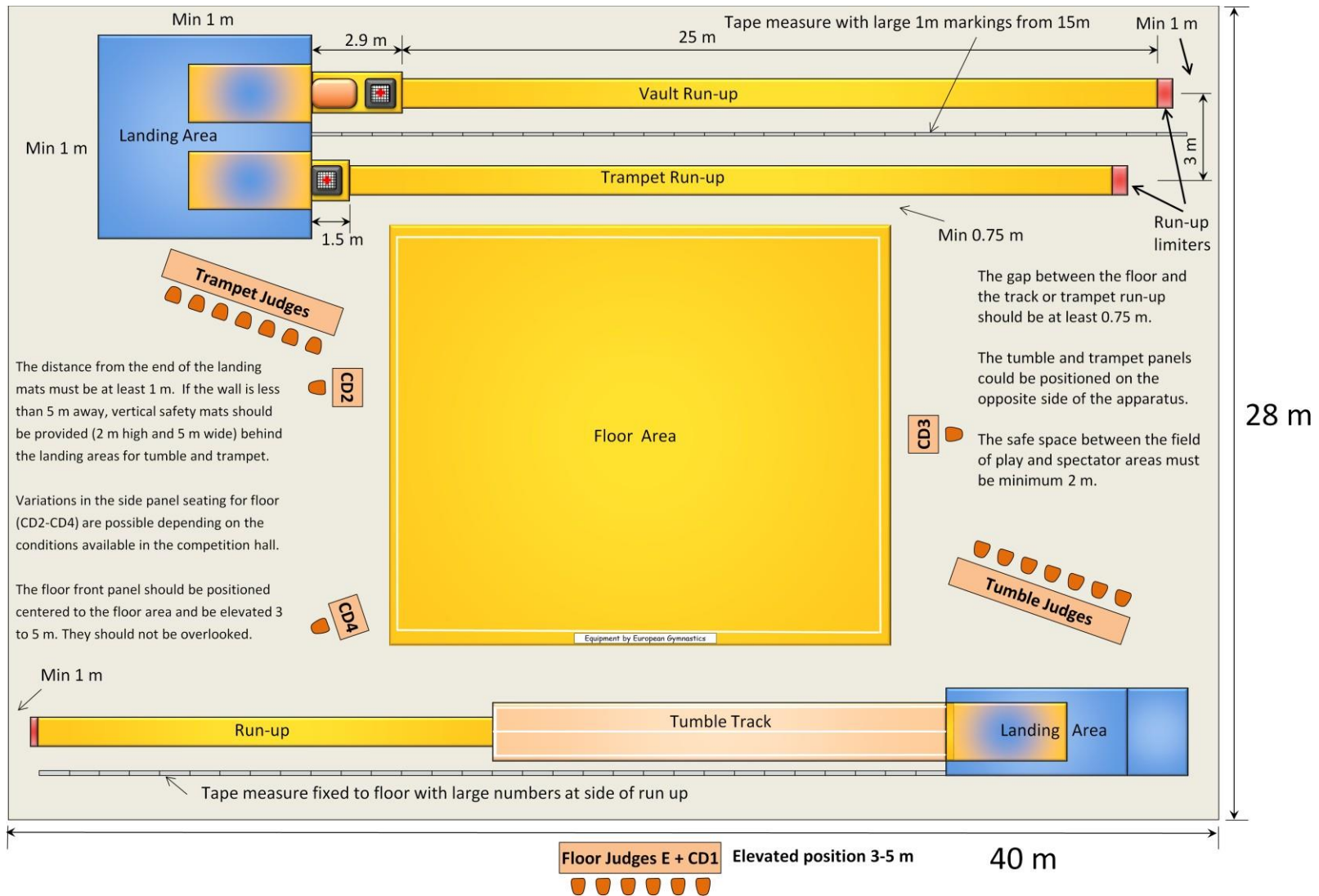

Appendix A2 Competition Equipment Dimensions

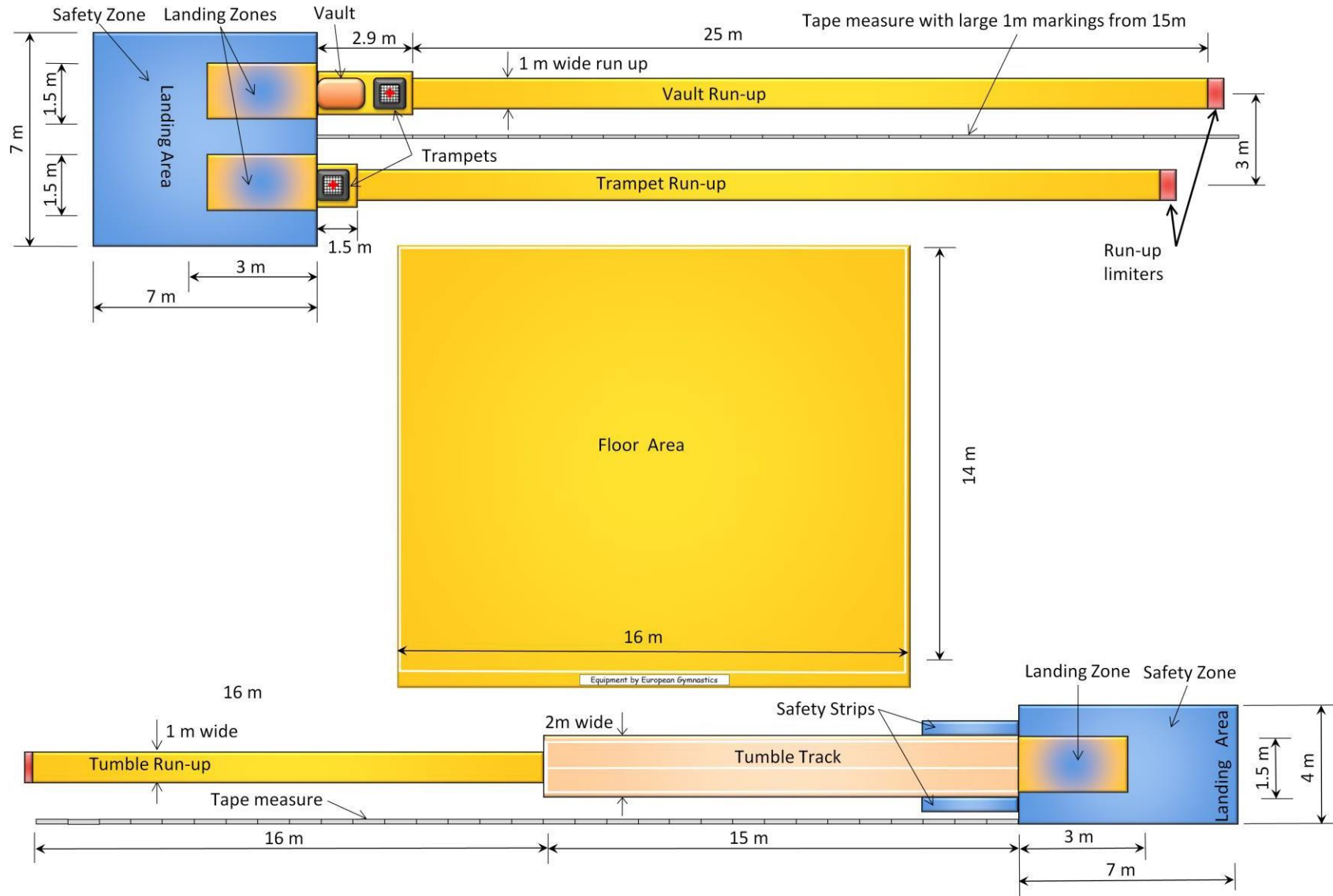

Appendix A3 Trampet and Vault Details

Trampet and Vault Set-up

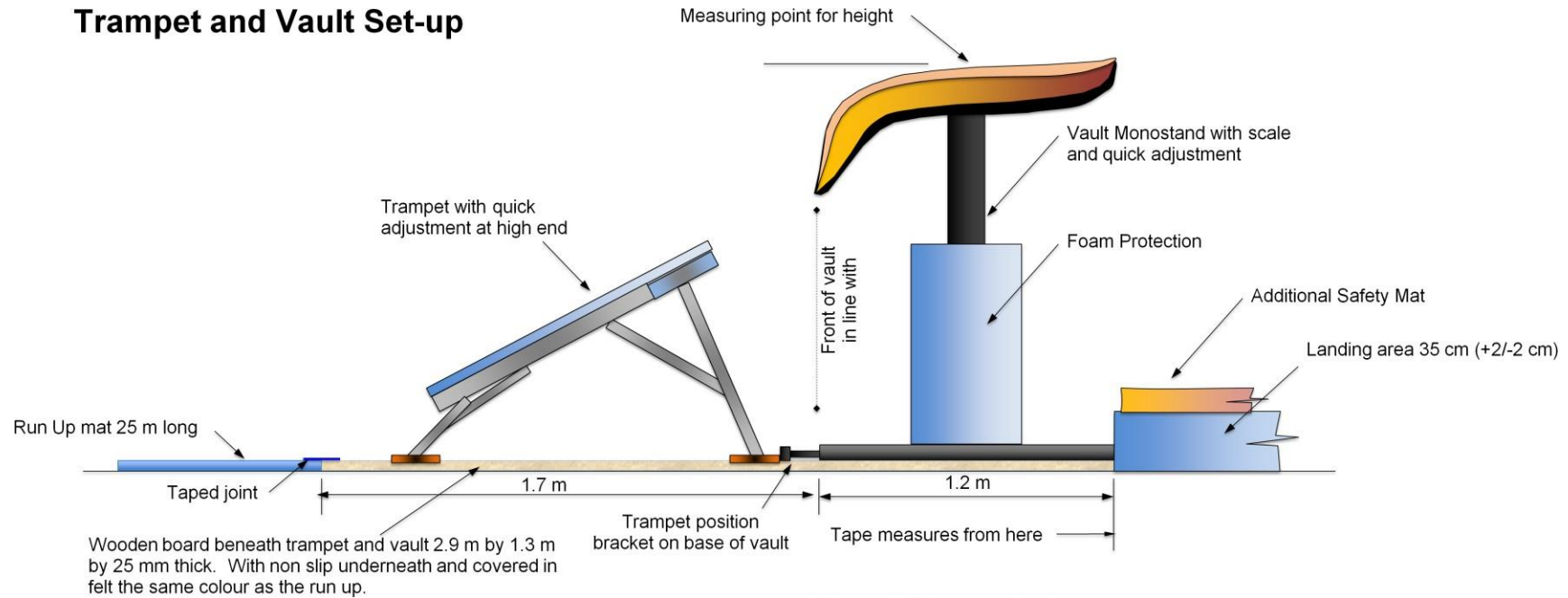

Trampet Stand Alone Set-up

